

INDUSTRY-SPECIFIC SOLUTIONS

FOUNDRIES

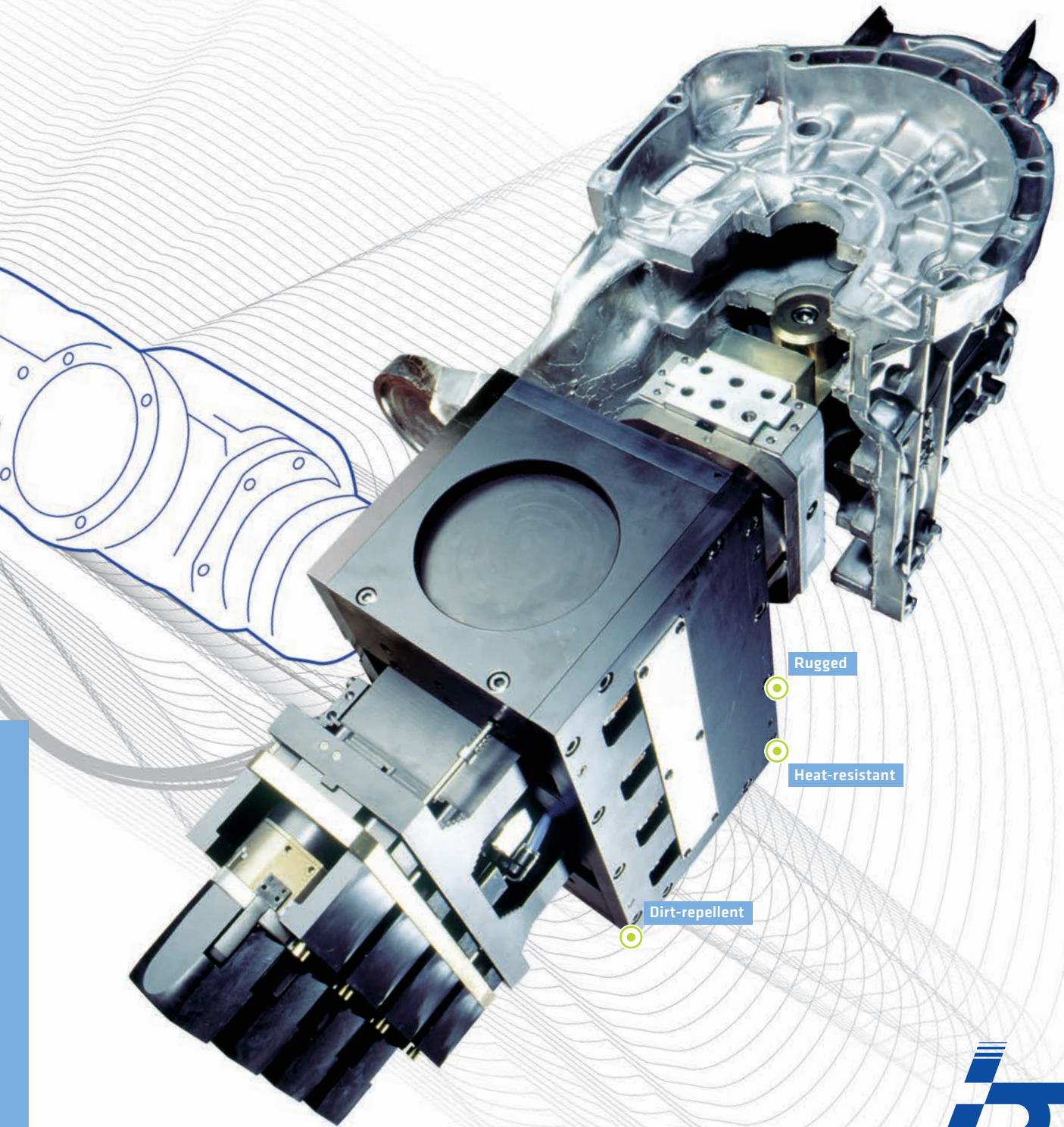

Rugged

Heat-resistant

Dirt-repellent

Intelligent solutions for a tough environment.

IPR: Your partner in foundry technologies.

To the fore in all manufacturing processes

Heat, moisture and dirt – IPR knows all too well about the extreme conditions prevailing in the foundry industry and the related requirements. With our gripper systems, robot transport units and fully automated manufacturing cells, we accompany all operations from chill, sand and precision casting, die casting and casting with salt core inserts through to the handling and assembling of delicate components or heavy molds.

Competence in equipment construction and as a system integrator

Our technological and industry knowledge also makes us a dependable partner in foundry equipment construction. We use our innovative solutions in fitting out equipment constructors and plant manufacturers all over the world. For our customers, we also devise and install complete cells for process automation in low-pressure casting and die casting processes.

We support you in various casting processes:

DIE CASTING

- Salt core insert | NEW
- Aluminum
- Magnesium

Experts in salt core handling.

Use our innovative gripper solutions to dependably operate your salt core handling assignments.

Thanks to our gripper technology successes across the most varied of industries, we are especially skilled in rupture-free extraction of salt cores from core casting machines and in their insertion into die-casting molds.

LOW-PRESSURE CASTING

- Sand casting incl. sand core handling
- Chill casting
- Precision casting

Bespoke solution competence.

Our different specialist teams implement the full process from devising ideas through to actual design and production. In so doing, we develop customized individual solutions based on our standard program. This results in a reduction of design and delivery times – with a similar reduction in costs.

In many countries throughout the world, IPR is directly involved both in development and production technologies of supplier industry companies, such as KS Huayu AluTech, Mahle and Nemak, and of car manufacturers, such as Audi, BMW, Daimler, Ford, GM and VW.

PRODUCT BENEFITS

- Rugged
- Heat-resistant
- Dirt-repellent
- High availability
- Long operating life



Assembly cell for sand cores

The cell automates both sand core assembling and handling. It consists of an assembly- and turntable, a core inserting and extracting gripper, an elevated robot transport unit and gripper stackers. Cylinder heads are made with the assembled sand cores.

Customized gripper as per casting process.



DIE CASTING

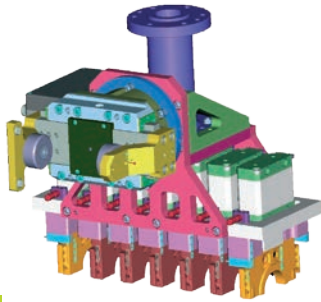

Magnetic bearing-support insert gripper

- Process** Aluminum die casting
- Customer** BMW
- Function** Inserting the bearing supports into the die-casting machine and extracting the bed plate
- Benefit** Reliable handling of cold and hot bearing supports using magnetic grippers

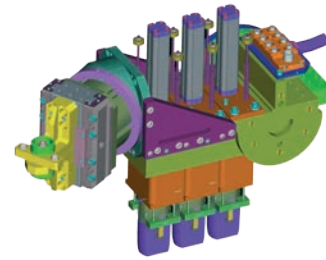

Bushings load and casted part unload gripper

- Process** Aluminum die casting
- Customer** Škoda
- Function** Inserting bushings into the die-casting machine and extracting the finished cylinder crankcase
- Benefit** No need for supply lines thanks to internal media transfer

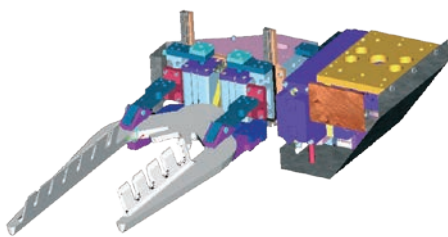

Conveyor unload and furnace feed gripper

- Process** Magnesium die casting
- Customer** BMW
- Function** Handling the sprue and of cylinder crankcases
- Benefit** Multifunctional

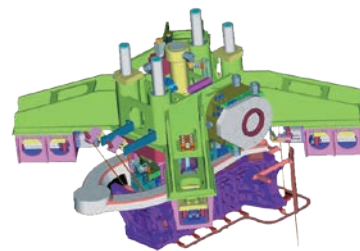

Load and unload gripper

- Process** Magnesium die casting
- Customer** BMW
- Function** Inserting and holding cylinder parts in the die-casting machine and extracting the finished cylinder crankcase
- Benefit** Putting in the inset under high pressing forces without any additional robot loading



LOW-PRESSURE CASTING



Coresetter for automated handling

- Customer** BMW
- Function** Fitting the finished core package in the mold
- Benefit** Raised level of availability due to precise gripper measuring and setting



Frame-gripper for sand cores

- Customer** Indianapolis Casting Company
- Function** Extracting sand cores from a core shooter and re-positioning them overhead
- Benefits**
- Optimum supply line protection brought about by internal frame piping
 - Frame construction for considerable stability



Assembly- and turntable for sand cores

The individual sand cores are assembled here into the core package. The Top Core is rotated by 180° for the final joining process. This prepositions the core package ready for pick-up by the coresetter.

Customized gripper as per casting process.



LOW-PRESSURE CASTING



Sand core insert gripper

Customer	KS Huayu AluTech
Function	Inserting water jacket cores into a chill mold
Benefit	Handling loosely combined sand cores

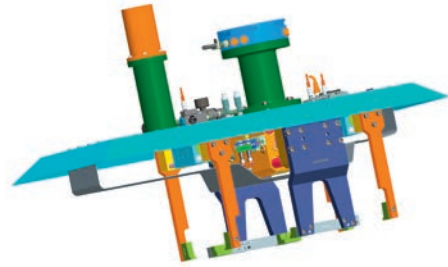

Unload gripper

Customer	KPSNC
Function	Extracting cylinder heads from the chill mold
Benefits	<ul style="list-style-type: none"> ■ Heat resistant and dirt repellent ■ Process-assured handling with positive-locked grippers

Robot transport units (RTUs)

In view of the extreme environmental conditions, our robot transport units for the foundry industry optionally come with an integrated air curtain using seal air to stop any rail contamination. Furthermore, a cover can protect the drive and control system of the unit and at the same time make it accessible.

Based on a basic module – two meter length with a one meter travel path – the IPR robot transport units are nearly endlessly extendable. Ten different aluminum or steel models are available with maximum payloads of up to 12 t.

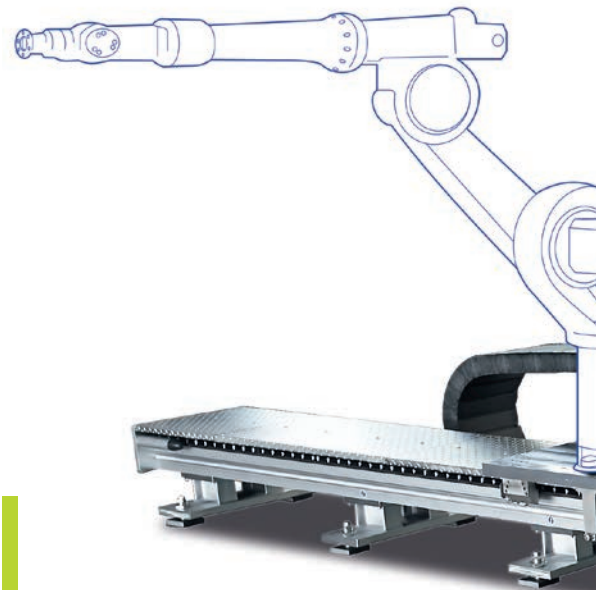



HANDLING



Crankcase handling gripper

- Customer** VW China
- Function** Handling cylinder crankcases
- Benefits**
- Raised level of availability
 - Long-stroke gripper with mechanical gripping force safeguard

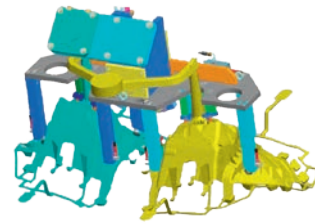

Multi-gripper for strut domes

- Customer** Daimler
- Function**
1. Extraction of cast part from die-casting machine with a single jaw gripper at the sprue
 2. Insertion into de-burring press
 4. Extraction of finished parts from de-burring press using vacuum or parallel grippers, sprue extraction using the single jaw gripper
- Benefit** Multifunctional

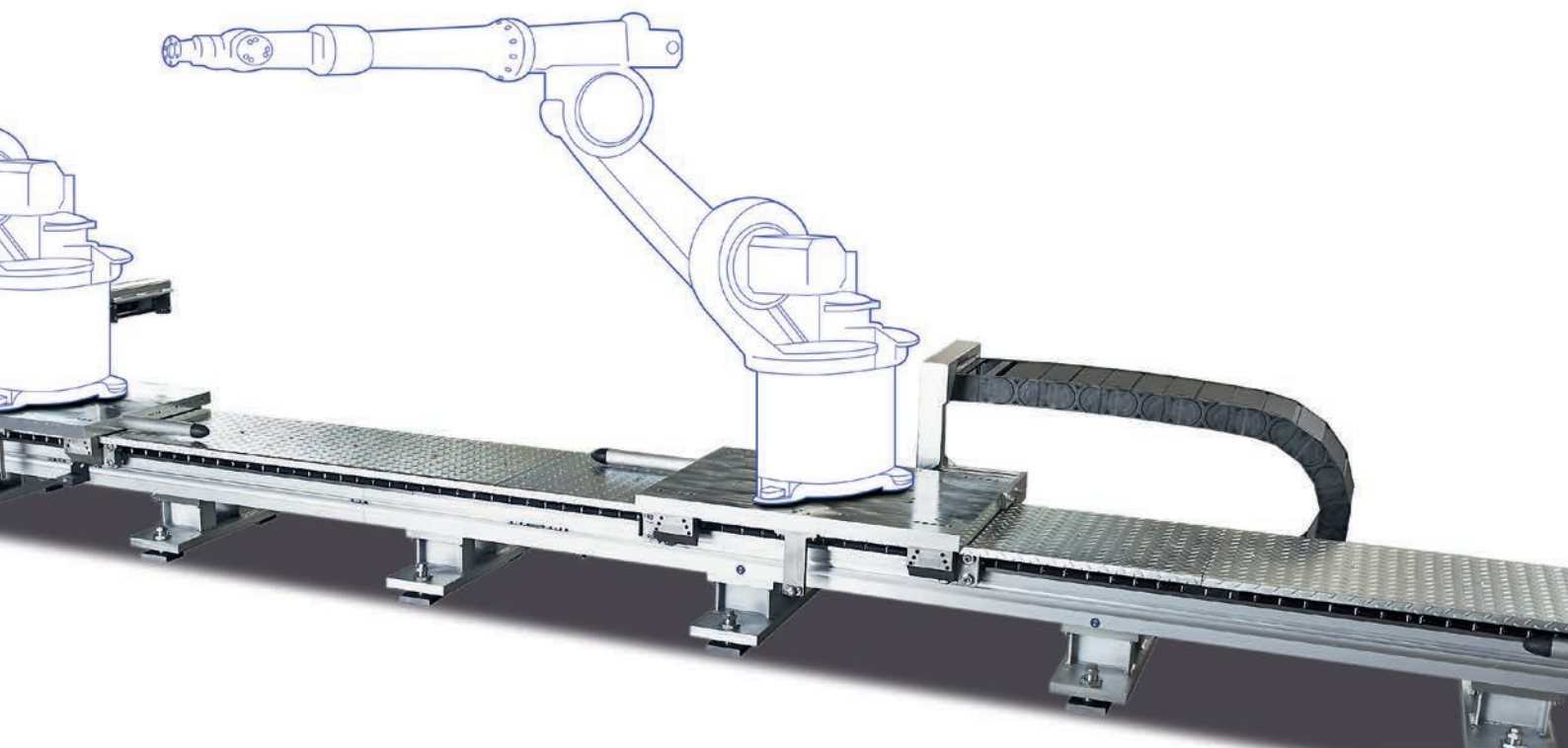

IPR – Intelligente Peripherien für Roboter GmbH

Jakob-Dieffenbacher-Str. 4/2
75031 Eppingen
Germany

T +49 7262 9239-100
F +49 7262 9239-400

info@iprworldwide.com
www.iprworldwide.com

We are represented across the globe.



USA

IPR Robotics, Inc.
2673 American Drive
Troy, MI 48083
T +1 248 556-7556
F +1 248 556-7560
techsales@iprrobotics.com

Mexico

Intellum, S.A. de C.V.
Av. Central 206, 1er piso
Col. San Pedro de los Pinos
Del. Alvaro Obregon, CP 01180
T +52 55 5668 6063
F +52 55 5668 6079
info@iprmexico.com

China

IPR GmbH
China Representative Office
Room C2119, Tomson Center
No 188, ZangYang Road
Pudong, Shanghai 200120
T +86 21 5876 9833
F +86 21 5876 9941
zd.huang@ipr-soehner.sina.net



More contacts can be found under:
www.iprworldwide.com/en